

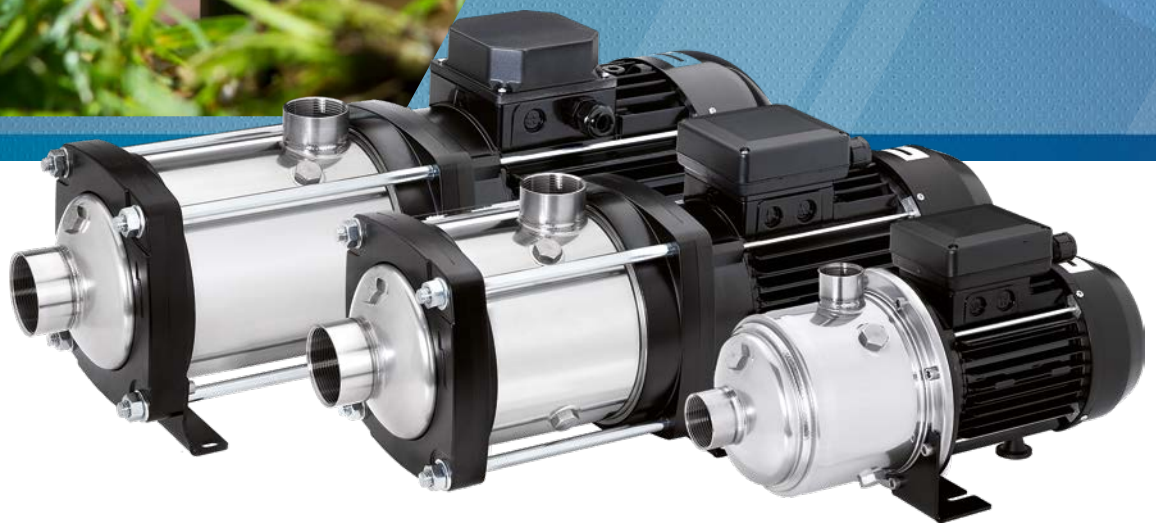

EH - EHsp SERIES 50 Hz

HORIZONTAL MULTISTAGE AND SELF-PRIMING PUMPS



EHsp 3 - TECHNICAL DATA

1 ~ ELECTRIC PUMP TECHNICAL DATA

Pump model	Motor size	MOTOR NOMINAL POWER		INPUT POWER [kW]	Capacitor 450V μ F	INPUT CURRENT [A] 220-240 V	Dimensions [mm]		Weight [Kg]
		[kW]	[HP]				A	F	
EHsp 3/4	71	0.55	0.75	0.79	16	3.8	175	433	12.6
EHsp 3/5	71	0.75	1	0.95	16	4.5	199	457	13

3 ~ ELECTRIC PUMP TECHNICAL DATA

Pump model	Motor size	MOTOR NOMINAL POWER		INPUT POWER [kW]	INPUT CURRENT [A] 220-240 V	Dimensions [mm]		Weight [Kg]
		[kW]	[HP]			A	F	
EHsp 3/4 T	71	0.75	1	0.75	2.4	175	435	12.2
EHsp 3/5 T	71	0.75	1	0.91	2.8	199	459	12.8

DIMENSIONAL DRAWINGS

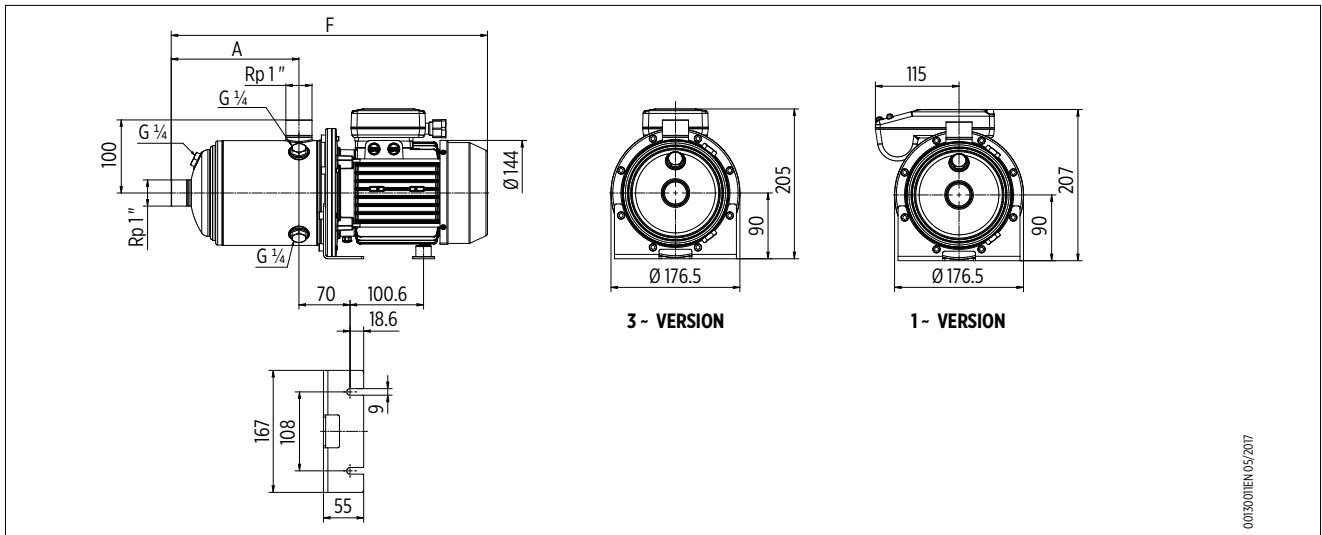

EHsp 5 - TECHNICAL DATA

1 ~ ELECTRIC PUMP TECHNICAL DATA

Pump model	Motor size	MOTOR NOMINAL POWER		INPUT POWER [kW]	Capacitor 450V μ F	INPUT CURRENT [A] 220-240 V	Dimensions [mm]		Weight [kg]
		[kW]	[HP]				A	F	
EHsp 5/4	71	0.9	1.2	1.10	30	5.3	175	433	14
EHsp 5/5	71	1.1	1.5	1.31	30	6.1	199	457	14.4

3 ~ ELECTRIC PUMP TECHNICAL DATA

Pump model	Motor size	MOTOR NOMINAL POWER		INPUT POWER [kW]	INPUT CURRENT [A] 220-240 V	Dimensions [mm]		Weight [Kg]
		[kW]	[HP]			A	F	
EHsp 5/4 T	71	1.1	1.5	0.99	3.2	175	435	12.8
EHsp 5/5 T	71	1.1	1.5	1.20	3.7	199	459	13.4

DIMENSIONAL DRAWINGS

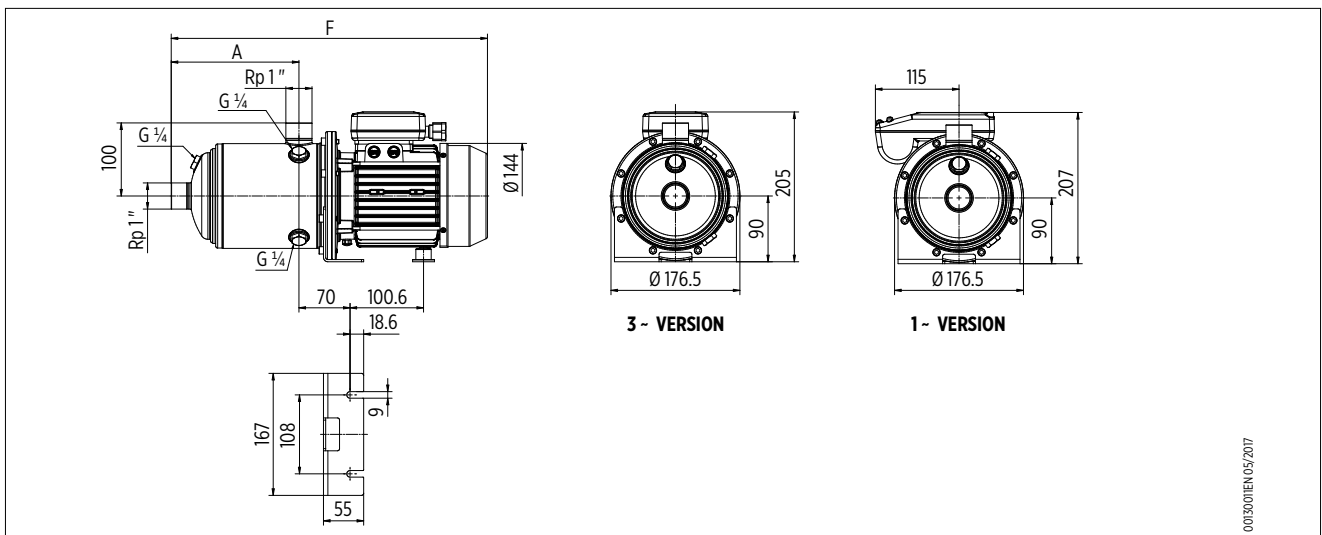

0003001EN/05/2017

EHsp 5 - PERFORMANCE CURVES 50 HZ

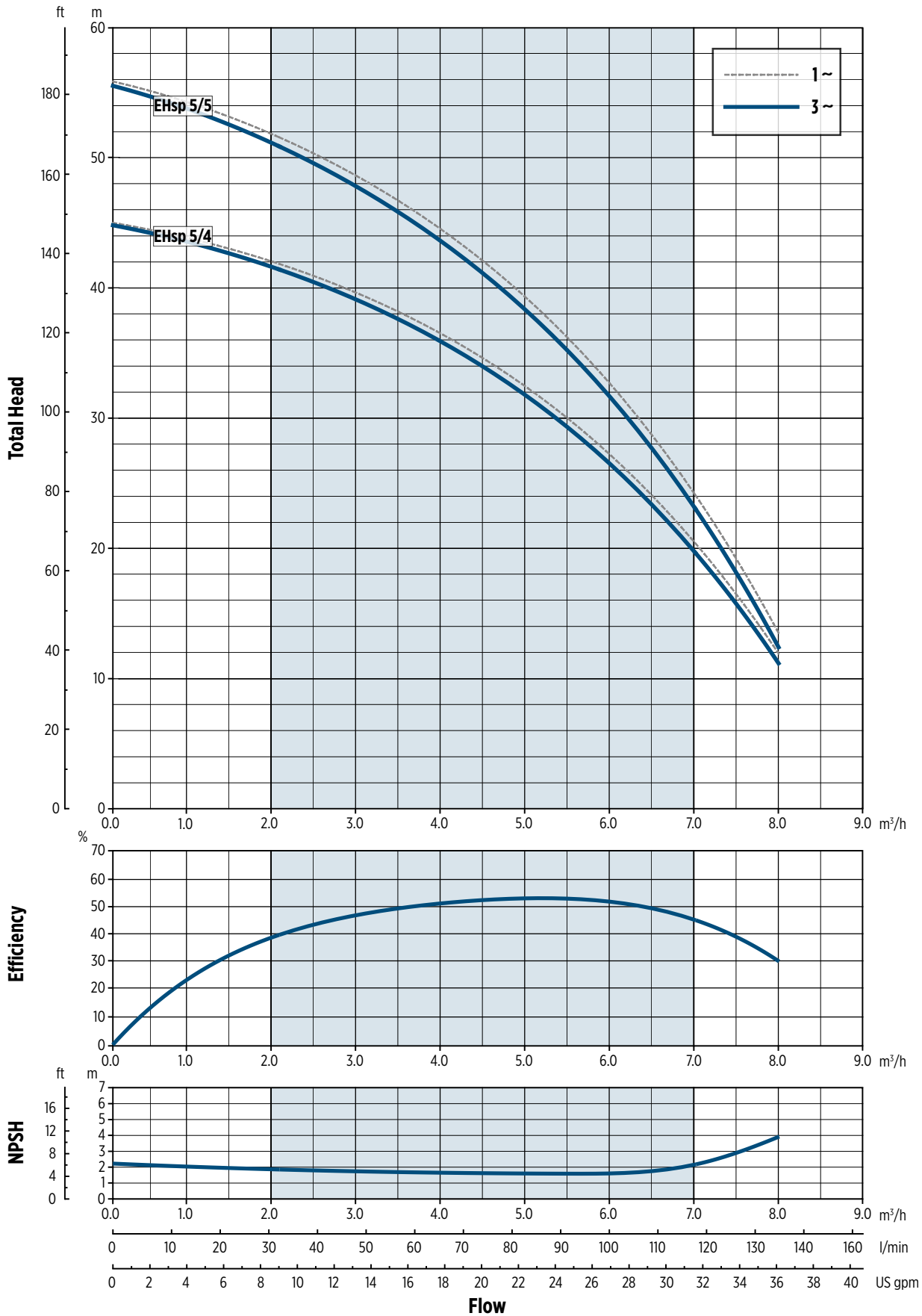

HYDRAULIC CHARACTERISTICS

